

Using the MAX4090 with the Reconstruction Filter

In most video applications, the video signal generated from the DAC requires a reconstruction filter to smooth out the signal and attenuate the sampling aliases. The MAX4090 is a direct, DC-coupled output driver, which can be used after the reconstruction filter to drive the video signal. The driving load from the video DAC can be varied from 75 to 300Ω. A low input impedance (<100Ω) is required by the MAX4090 in normal operation, special care must be taken when a reconstruction filter is used in front of the MAX4090.

For standard video signal, the video pass-band is about 6MHz and the system over-sampling frequency is at 27MHz. Normally, A 9MHz BW low pass filter is required for the reconstruction filter. The following paragraphs talk about the methods to build simple 2nd and 3rd order passive butterworth low pass filters at 9MHz cutoff frequency and the techniques to use them with the MAX4090 (Figure 1 and Figure 4).

2nd Order Butterworth Low Pass Filter Realization

Table 1 shows the normalized 2nd order butterworth LPF component values at 1rad/s with a source/load impedance of 1Ω.

Table 1

Rn1 = Rn2 (Ω)	Cn1(F)	Ln1(H)
1	1.414	1.414

With the following equations, the L and C can be calculated for the cutoff frequency at 9MHz. Table 2 shows the appropriated L and C values for different source/load impedance and the bench measurement values for the -3dB BW and attenuation at 27MHz. There is approximately 20dB attenuation at 27MHz, which attenuates the sampling aliases effectively. The MAX4090 requires low input impedance for stable operation and it doesn't like the reactive input impedance. For R1/R2 greater than 100Ω, a series resistor Ris (Figure 1) between 20 to 100Ω is needed to isolate the input capacitor (C4) to the filter to prevent the oscillation problem.

$$C = \frac{C_n}{2\pi f_c R_L} \quad L = \frac{L_n R_L}{2\pi f_c}$$

Table 2

R1 =R2 (Ω)	C1(pF)	L1(μ H)	Ris (Ω)	3dB BW(MHz)	Attenuation at 27MHz(dB)
75	330	1.8	0	8.7	20
150	150	3.9	50	9	20
200	120	4.7	50	9.3	22
300	82	8.2	100	8.7	20

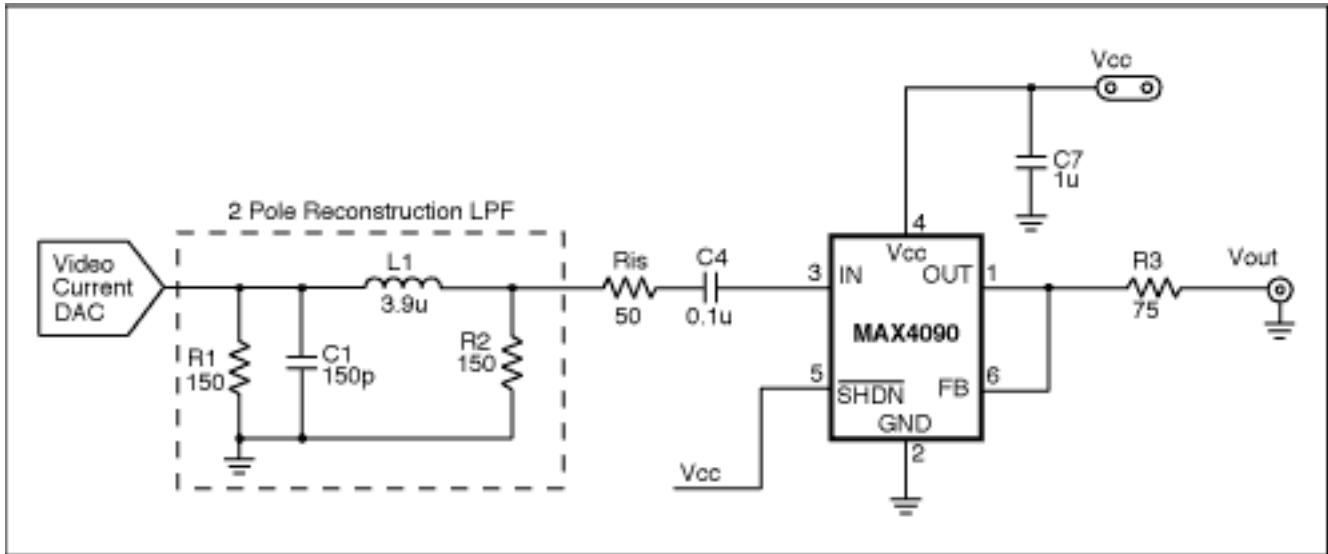

Figure 1.

Figure 2 shows the frequency response for $R1=R2=150\Omega$. At 6MHz, the attenuation is about 1.4dB. The attenuation at 27MHz is about 20dB. Figure 3 shows the multiburst response for $R1=R2=150\Omega$.

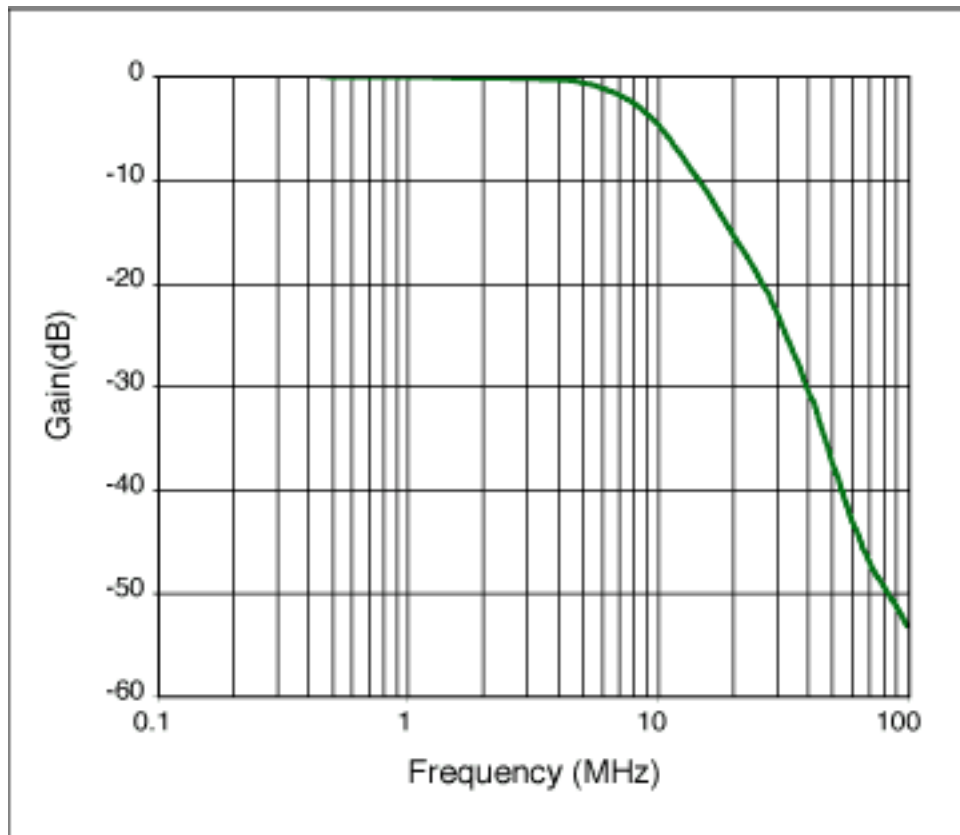

Figure 2. Frequency Response.

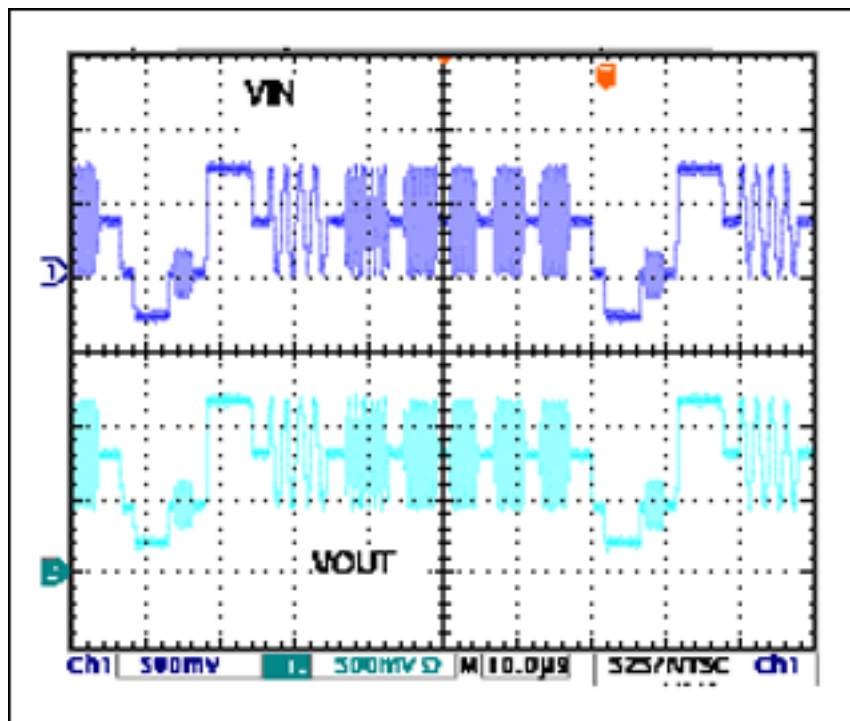

Figure 3. Multiburst Response.

3rd Order Butterworth Low Pass Filter realization

If more flat pass-band and more stop band attenuation are needed, a 3rd order LPF can be used.

Table 3 shows the normalized 3rd order butterworth low pass filter with the cut off frequency at 1 rad/s and the stop band frequency at 3 rad/s. Table 4 shows the appropriated L and C values for different source/load impedance and the bench measurement values for -3dB BW and attenuation at 27MHz. The attenuation is over 40 dB at 27MHz. At 6MHz, the attenuation is approximately 0.6dB for R1=R2=150W (Figure 5).

Table 3

Rn1 = Rn2 (Ω)	Cn1(F)	Cn2(F)	Cn3(F)	Ln1(H)
1	0.923	0.923	0.06	1.846

Table 4

R1 =R2 (Ω)	C1(pF)	C2(pF)	C3(pF)	L(μ H)	Ris (Ω)	3dB BW(MHz)	Attenuation at 27MHz(dB)
75	220	220	15	2.2	0	9.3	43
150	120	120	6.8	4.7	50	8.9	50
300	56	56	3.3	10	100	9	45

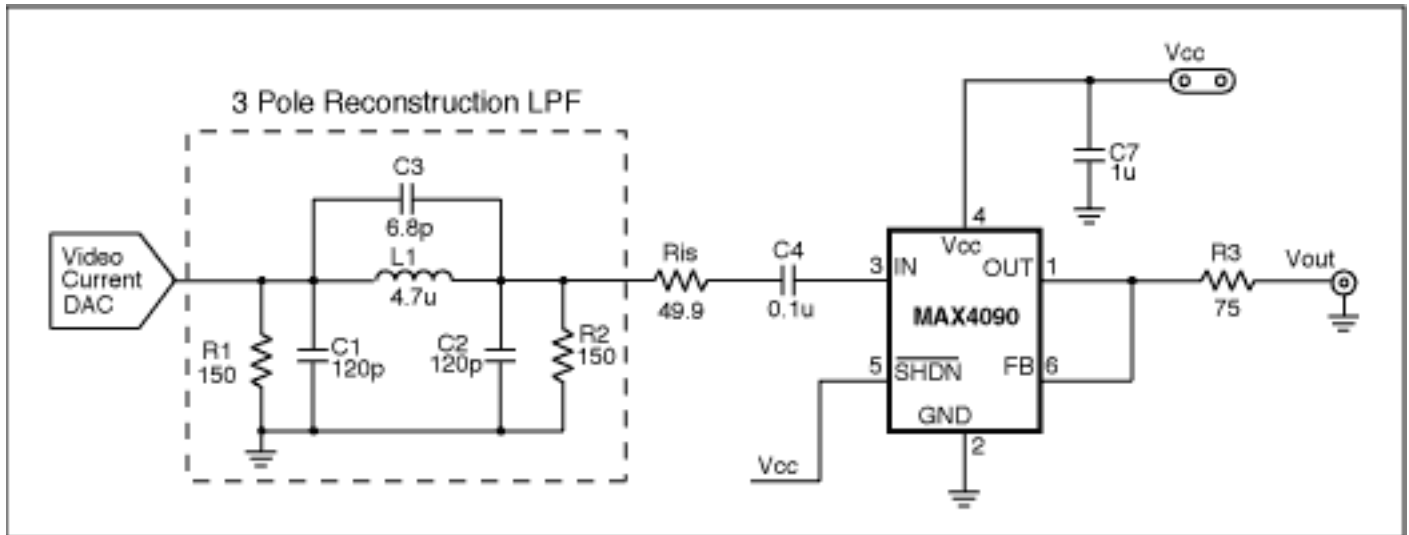

Figure 4.

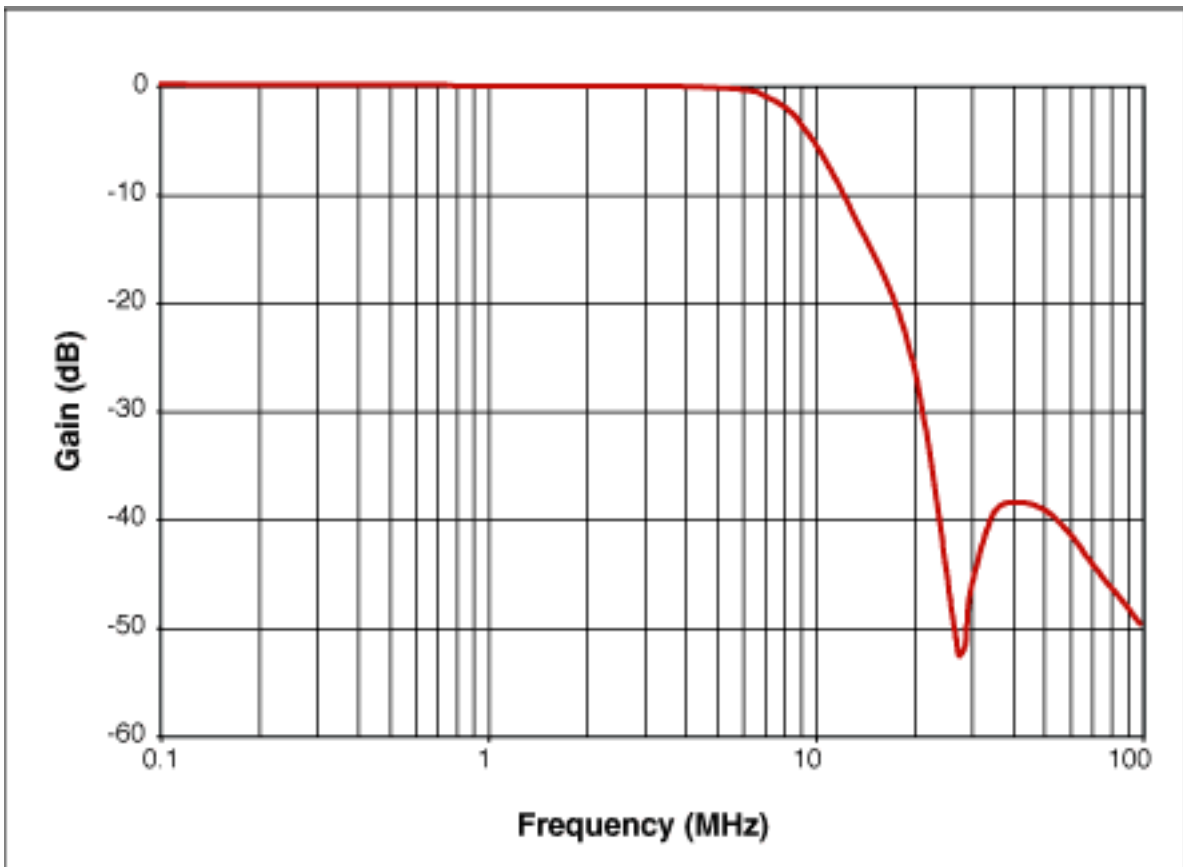

Figure 5.

Sag Correction

In a 5V application, the MAX4090 can use the Sag configuration if an AC coupled output video signal is required. Sag correction refers to the low frequency compensation for the highpass filter formed by the 150 ohm load and the output capacitor. In video application, the cutoff frequency must be low enough to pass the vertical Sync interval to avoid field tilt. This cutoff frequency should be less than 3 to 5Hz, and the coupling capacitor must be very large in normal configuration, typically > 220uF. In Sag configuration, the MAX4090 eliminates the need for large coupling capacitor, and instead requires two 22uF capacitors (Figure 6). Bench experiment shows that increasing the output coupling capacitor C5 beyond 47uF doesn't improve the performance. If the supply voltage is less than 4.5V, the Sag correction is not recommended for the MAX4090.

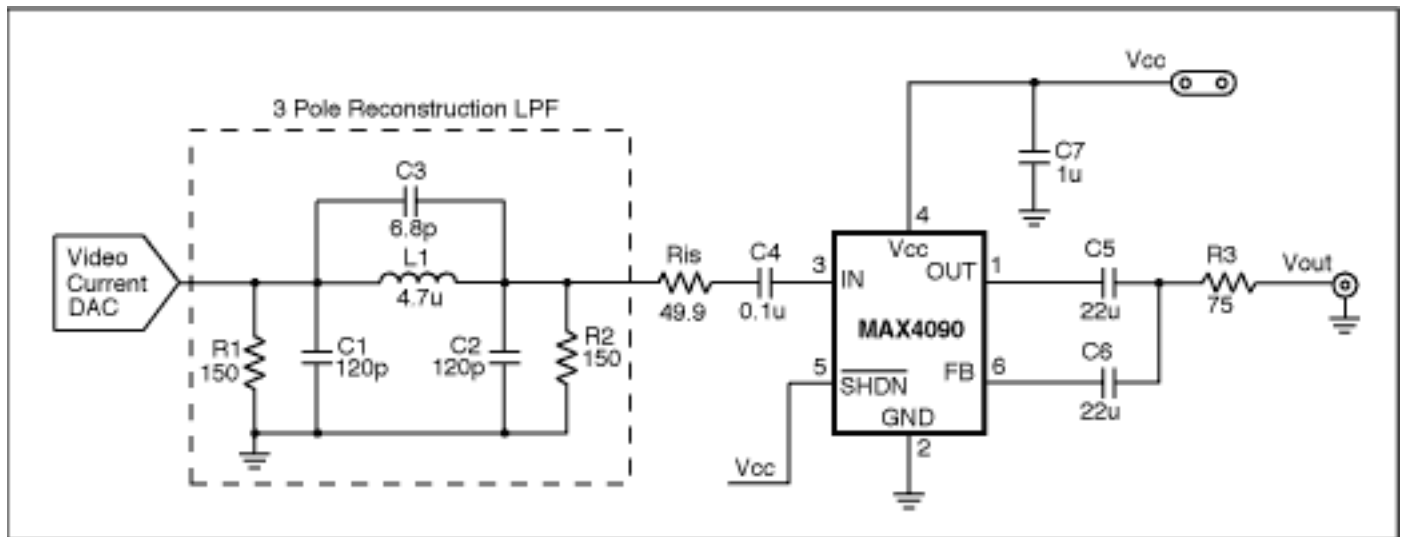

Figure 6.

More Information

MAX4090: [QuickView](#) -- [Full \(PDF\) Data Sheet](#) -- [Free Samples](#)